

Product Portfolio



LEAN LOGISTICS

The backbone of Lean manufacturing

Index

Lean Dolly Type I	4
Lean Dolly Type II.....	5
Lean Dolly Type III	6
Lean Dolly Type V	7
Lean Dolly Type VII.....	8
Lean Dolly Type VIIC with elevated deck	9
Lean Dolly 800 x 600 mm.....	10
Lean Dolly 1200 x 800 mm.....	11
Lean Dolly 600 x 800 mm.....	12
Lean Adaptor Pallet	13
Lean Pallet Size Dolly.....	14
Mini Lean Pallet Size Dolly	15
Lean Pallet Size Dolly with elevated deck.....	16
Lean Shelf Wagon	17
Lean Taxiliner.....	18
LiftLiner®	20
elephantboard® and daughter cart for the LiftLiner®	21
Accessories – Wheel overview	22
Accessories – Safety and ergonomics	23
Accessories – Dirt prevention.....	24
Accessories – Connecting devices	25
A-MATE®	26
Electric Tugs	28
Ergonomic lifters and supermarkets.....	29
Floor marking, visual management and Monorail Systems	30
SG monomover	31



Keep things rolling with Lean Logistics

Benefits

- Improve work flow
- Reduce handling costs
- Enable reduction of stock level
- Reduce need for floor space
- Improve ergonomics
- Fast and safe truck loading

Lean Dolly Type I



TECHNICAL SPECIFICATION	
External dimensions	600 x 400 x 162 mm
Tare weight with CPD wheels, no corners	6,5 kg
Wheel size	100 mm wheels
Wheel configuration	2 fixed & 2 swivel
Wheel material	CPD, rubber or PU
Working capacity	
- CPD – standard and ESD	250 kg
- Rubber – standard and ESD	250 kg
- PU – standard and ESD	250 kg
Surface treatment	Blue zinc plated acc. to EN-ISO2081
Safe stacking	up to 15 units (1950 mm)
Compatibility with Lean Adaptor Pallets	Next Generation (HADP10030, HADP10032, HADP10045)

OPTIONS

- Total brake on 1 or 2 swivel wheels
- RFID & Tracking compatibility
- Corner supports
- ESD compatibility

ALSO AVAILABLE IN ISO- AND US-DIMENSIONS

- 600 x 500 mm
- 24" x 15"
- 24" x 22.5"

DESIGNED TO CARRY SLC'S AND TRAYS

- 1 stack of 600 x 400 mm
- 2 stacks of 300 x 400 mm
- 4 stacks of 300 x 200 mm

ACCESSORIES

- Ergonomic handle
- Strapping device
- Oil dripping pan



Watch the video

Lean Dolly Type II



www.tuv.com
ID 0000040591



TECHNICAL SPECIFICATION

External dimensions	600 x 400 x 162 mm
Tare weight with CPD wheels, no corners	7,0 kg
Wheel size	100 mm wheels
Wheel configuration	4 swivel
Wheel material	CPD, rubber or PU
Working capacity:	
- CPD – standard and ESD	250 kg
- Rubber – standard and ESD	250 kg
- PU – standard and ESD	250 kg
Surface treatment	Blue zinc plated acc. to EN-ISO2081
Safe stacking	up to 15 units (1950 mm)
Compatibility with Lean Adaptor Pallets	Next Generation (HADP10030, HADP10032, HADP10045)

OPTIONS

- Total brake on 1 or 2 swivel wheels
- RFID & Tracking compatibility
- Corner supports
- ESD compatibility

ALSO AVAILABLE IN ISO- AND US-DIMENSIONS

- 600 x 500 mm
- 24" x 15"
- 24" x 22.5"

DESIGNED TO CARRY SLC'S AND TRAYS

- 1 stack of 600 x 400 mm
- 2 stacks of 300 x 400 mm
- 4 stacks of 300 x 200 mm

ACCESSORIES

- Ergonomic handle
- Strapping device
- Oil dripping pan



Watch
the video

Lean Dolly Type III



With 4 swivel wheels



TECHNICAL SPECIFICATION	
External dimensions	400 x 400 x 178,5 mm
Tare weight with CPD wheels	6 kg
Wheel size	100 mm wheels
Wheel configuration	2 fixed & 2 swivel or 4 swivel
Wheel material	CPD, rubber or PU
Working capacity:	
- CPD – standard and ESD	160 kg
- Rubber – standard and ESD	160 kg
- PU – standard and ESD	160 kg
Surface treatment	Blue zinc plated acc. to EN-ISO2081
Safe stacking	up to 8 units (1200 mm)
Compatibility with Lean Adaptor Pallets	Next Generation (HADP10030, HADP10032, HADP10045)

OPTIONS

- Total brake on 1 or 2 swivel wheels
- RFID & Tracking compatibility
- ESD compatibility

DESIGNED TO CARRY SLC'S AND TRAYS

- 1 stack of 400 x 400 mm

ACCESSORIES

- Ergonomic handle
- Strapping device



Watch the video

Lean Dolly Type V



TECHNICAL SPECIFICATION	
External dimensions	604 x 404 x 157 mm
Tare weight with CPD wheels, with corners	7,5 kg
Wheel size	100 mm wheels
Wheel configuration	4 swivel
Wheel material	CPD, rubber or PU
Working capacity:	
- CPD – standard and ESD	250 kg
- Rubber – standard and ESD	250 kg
- PU – standard and ESD	250 kg
Surface treatment	Blue zinc plated acc. to EN-ISO2081
Safe stacking	up to 15 units (1950 mm)
Compatibility with Lean Adaptor Pallets	Next Generation (HADP10030, HADP10032, HADP10045)

OPTIONS

- Total brake on 1 or 2 swivel wheels
- RFID & Tracking compatibility
- ESD compatibility

ALSO AVAILABLE IN ISO- AND US-DIMENSIONS

- 600 x 500 mm
- 24" x 15"
- 24" x 22.5"

DESIGNED TO CARRY SLC'S AND TRAYS

- 1 stack of 600 x 400 mm
- 2 stacks of 300 x 400 mm
- 4 stacks of 300 x 200 mm

ACCESSORIES

- Ergonomic handle
- Strapping device
- Oil dripping pan



Watch
the video

Lean Dolly Type VII



With sliding draw bar system



www.tuv.com
ID 0000040591



TECHNICAL SPECIFICATION	
External dimensions	604 x 404 x 162 (382) mm
Tare weight with CPD wheels, no corners	7 kg
Wheel size	100 mm wheels
Wheel configuration	2 fixed & 2 swivel
Wheel material	CPD, rubber or PU
Maximum Load Capacity:	
- CPD – standard and ESD	250 kg
- Rubber – standard and ESD	250 kg
- PU – standard and ESD	250 kg
Working capacity in tugger train	1000 kg
Max amount per tugger train	7–8 units
Surface treatment	Blue zinc plated acc. to EN-ISO2081
Safe stacking	up to 15 units (1955 mm)
Compatibility with Lean Adaptor Pallets	Next Generation (HADP10030, HADP10032, HADP10045)
Recommended max speed	6 km/h

OPTIONS

- Total brake on 1 or 2 swivel wheels
- RFID & Tracking compatibility
- Corner supports
- Stealth version sliding tow system
- ESD compatibility

ALSO AVAILABLE IN ISO AND US-DIMENSIONS

- 600 x 500 mm, 24" x 15", 24" x 22.5"

DESIGNED TO CARRY SLC'S AND TRAYS

- 1 stack of 600 x 400 mm
- 2 stacks of 300 x 400 mm
- 4 stacks of 300 x 200 mm

ACCESSORIES

- Ergonomic handle
- Strapping device
- Oil dripping pan



Watch the video

Lean Dolly Type VIIC with elevated deck



TECHNICAL SPECIFICATION	
External dimensions	612 x 404 x 683 mm
Tare weight with CPD wheels, no corners	18 kg
Wheel size	100 mm wheels
Wheel configuration	2 fixed & 2 swivel
Wheel material	CPD, rubber or PU
Maximum Load Capacity:	
- CPD – standard and ESD	70 kg
- Rubber – standard and ESD	70 kg
- PU – standard and ESD	70 kg
Working capacity in tugger train	1000 kg
Max amount per tugger train	7–8 units
Surface treatment	Blue zinc plated acc. to EN-ISO2081
Safe stacking	up to 3 units (1955 mm)
Compatibility with Lean Adaptor Pallets	Next Generation (HADP10030, HADP10032, HADP10045)
Recommended max speed	4 km/h

OPTIONS

- Total brake on 1 or 2 swivel wheels
- RFID & Tracking compatibility
- ESD compatibility

DESIGNED TO CARRY SLC'S AND TRAYS

- 1 stack of 600 x 400 mm
- 2 stacks of 300 x 400 mm
- 4 stacks of 300 x 200 mm

ACCESSORIES

- Ergonomic handle
- Oil dripping pan



Watch
the video

Lean Dolly 600 x 800 mm

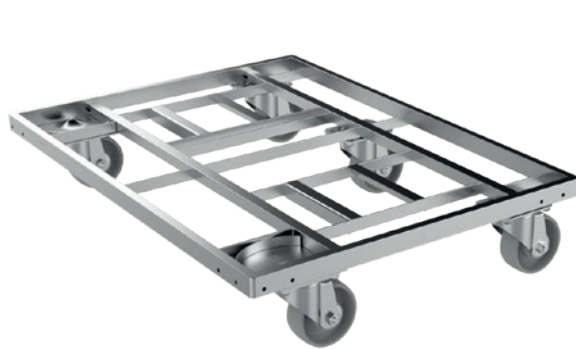

With 5 swivel wheels



With draw bar



With draw bar and plywood deck



www.tuv.com
ID 0000040591



TECHNICAL SPECIFICATION	
External dimensions	600 x 806 x 158 (495) mm
Tare weight with CPD wheels	12 kg
Wheel size	100 mm wheels
Wheel configuration	2 fixed & 3 swivel or 5 swivel
Wheel material	CPD, rubber or PU
Maximum Load Capacity:	
- CPD – standard and ESD	500 kg
- Rubber – standard and ESD	500 kg
- PU – standard and ESD	500 kg
Working capacity in tugger train	1600 kg
Max amount per tugger train	5–6 units
Surface treatment	Blue zinc plated acc. to EN-ISO2081
Safe stacking	up to 15 units (1955 mm) with towing arm 2,3 m
Compatibility with Lean Adaptor Pallets	Next Generation (HADP10030, HADP10032, HADP10045)
Recommended max speed	6 km/h

OPTIONS

- Total brake on 1 or 2 swivel wheels
- RFID & Tracking compatibility
- Corner supports
- Draw bar
- ESD compatibility

ALSO AVAILABLE IN ISO-DIMENSIONS

- 600 x 1000 mm

DESIGNED TO CARRY SLC'S AND TRAYS

- 1 stack of 600 x 800 mm
- 2 stack of 600 x 400 mm
- 4 stacks of 300 x 400 mm
- pallets, foldable cages and stillages

ACCESSORIES

- Strapping device
- Multipurpose plywood deck



Watch
the video

Lean Dolly 1200 x 800 mm



TECHNICAL SPECIFICATION	
External dimensions	1212 x 800 x 162 (502) mm
Tare weight with CPD wheels	19 kg
Wheel size	100 mm wheels
Wheel configuration	2 fixed & 4-5 swivel
Wheel material	CPD, rubber or PU
Maximum Load Capacity:	
- CPD – standard and ESD	4 swivel 300 kg 5 swivel 500 kg
- Rubber – standard and ESD	4 swivel 300 kg 5 swivel 500 kg
- PU – standard and ESD	4 swivel 300 kg 5 swivel 500 kg
Working capacity in tugger train	1600 kg
Max amount per tugger train	5–6 units
Surface treatment	Blue zinc plated acc. to EN-ISO2081
Safe stacking	up to 15 units (1955 mm) with towing arm 2,3 m
Compatibility with Lean Adaptor Pallets	Next Generation (HADP10030, HADP10032, HADP10045)
Recommended max speed	6 km/h

OPTIONS

- Total brake on 1 or 2 swivel wheels
- RFID & Tracking compatibility
- Corner supports
- Draw bar
- ESD compatibility

DESIGNED TO CARRY SLC'S AND TRAYS

- 3 stacks of 800 x 400 mm
- 4 stack of 600 x 400 mm
- 8 stacks of 300 x 400 mm
- pallets, foldable cages and stillages

ACCESSORIES

- Strapping device
- Multipurpose plywood deck



Lean Dolly 800 x 600 mm

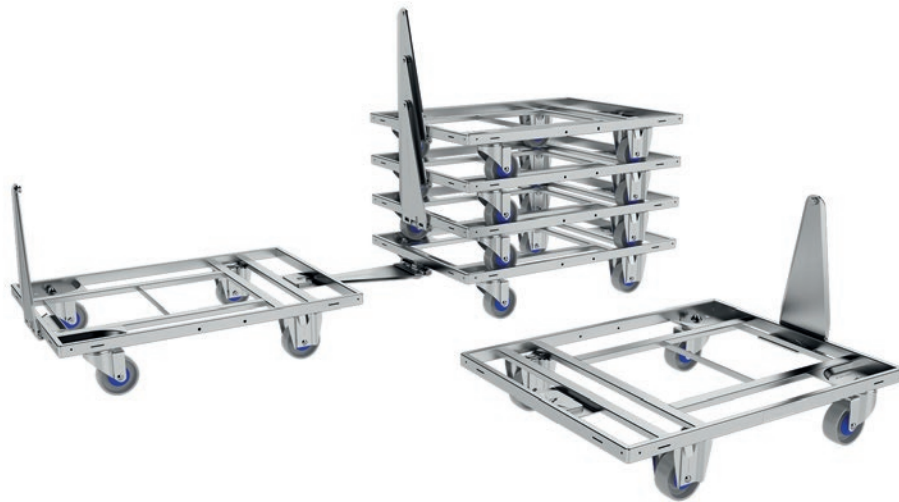

TECHNICAL SPECIFICATION	
External dimensions	800 x 600 x 162 (499) mm
Tare weight with CPD wheels	10,5 kg
Wheel size	100 mm wheels
Wheel configuration	2 fixed and 2 swivel
Wheel material	CPD, rubber or PU
Maximum Load Capacity:	
- CPD – standard and ESD	500 kg
- Rubber – standard and ESD	500 kg
- PU – standard and ESD	500 kg
Working capacity in tugger train	1600 kg
Max amount per tugger train	5–6 units
Surface treatment	Blue zinc plated acc. to EN-ISO2081
Safe stacking	up to 15 units (1955 mm) with towing arm 2,3 m
Recommended max speed	6 km/h

OPTIONS

- Total brake on 1 or 2 swivel wheels
- RFID & Tracking compatibility
- Corner supports
- Draw bar
- ESD compatibility

DESIGNED TO CARRY SLC'S AND TRAYS

- 2 stack of 600 x 400 mm
- 4 stacks of 300 x 400 mm
- pallets, foldable cages and stillages

ACCESSORIES

- Strapping device
- Multipurpose plywood deck



Watch
the video

Lean Adaptor Pallet

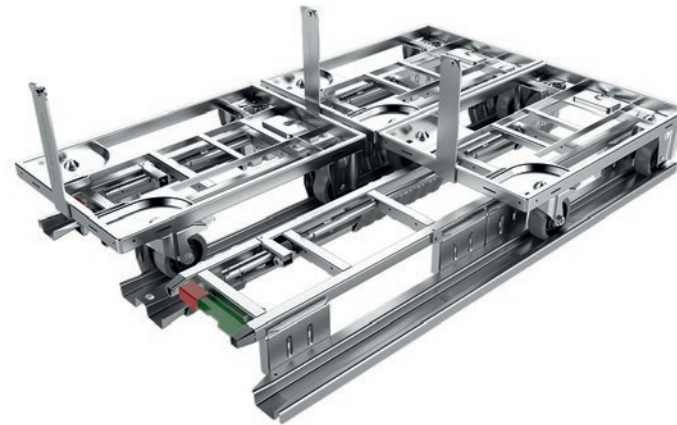
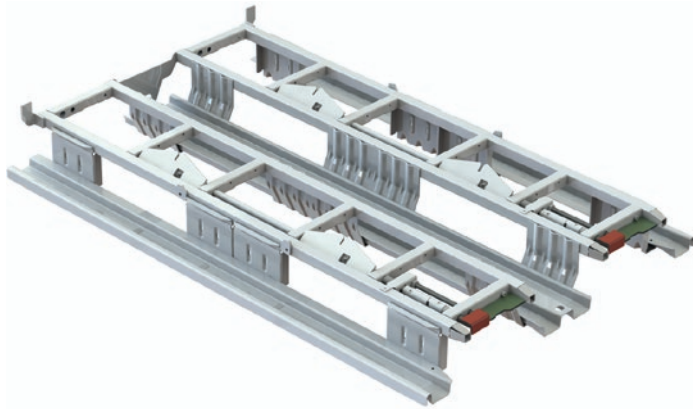

www.tuv.com
ID 0000040591



TECHNICAL SPECIFICATION

External dimensions	1210 x 800 x 149 mm
Tare weight	32 kg
Working capacity	1000 kg
Surface treatment	Blue zinc plated acc. to EN-ISO2081
Safe stacking	
- loaded in transport	2 units
- loaded at warehouse	3 units
- empty	15 units

DESIGNED FOR ALL STANDARD LEAN DOLLIES

OPTIONS

- Non-slip features
- RFID & Tracking compatibility
- ESD compatibility

ALSO AVAILABLE IN ISO AND US-DIMENSIONS

- 1200 x 1000 mm
- 48" x 30"
- 48" x 45"

ACCESSORIES

- EasyStrap
- Compatible with industry standard lids



Watch
the video

Lean Pallet Size Dolly



With 6 wheels
for 360° spinning



TECHNICAL SPECIFICATION	
External dimensions	1200 x 800 x 275 (1017) mm
Tare weight	66 kg
Wheel size	160 mm wheels
Wheel configuration	2 fixed & 2 swivel 4 swivel 2 fixed & 4 swivel
Wheel material	PU and CPD
Working capacity	1000 kg
Working capacity in tugger train	4000 kg
Max amount per tugger train	6 units
Surface treatment	Blue zinc plated acc. to EN-ISO2081
Safe stacking	up to 6 units (1680 mm) with "draw bar" (2,4 m)
Recommended max speed	6 km/h

COMPATIBLE WITH ALL LEAN DOLLIES, LEAN SHELF WAGON AND TAXILINER.

OPTIONS

- Available with anti slip material or plywood deck
- Integrated strapping device
- ESD compatibility
- Total brake on 1 or 2 swivel wheels
- RFID & Tracking compatibility
- Corner supports
- 360° spinning on 6 wheels
- Catch for towing one or two lines of Lean dollies
- Wheel spacer
- Forklift guide

ALSO AVAILABLE IN ISO- AND US-DIMENSIONS

- 1200 x 1000 mm (72 kg)
- 48" x 45" (77 kg)
- 32" x 30" (53 kg)

DESIGNED TO CARRY SLC'S, PALLETS AND BOXES

- Pallet sizes: Euro, ISO & 48" x 45"
- SLC's in Euro, ISO or US boxes
- Cages and foldable boxes



Watch
the video

Mini Lean Pallet Size Dolly



TECHNICAL SPECIFICATION	
External dimensions	923 x 600 x 280 (1019) mm
Tare weight	55 kg
Wheel size	160 mm wheels
Wheel configuration	2 fixed & 2 swivel or 4 swivel
Wheel material	PU and CPD
Working capacity	1000 kg
Working capacity in tugger train	4000 kg
Max amount per tugger train	6 units
Surface treatment	Blue zinc plated acc. to EN-ISO2081
Safe stacking	up to 6 units (1680 mm) with draw bar (2,4 m)
Recommended max speed	6 km/h

OPTIONS

- Available with anti slip material or plywood deck
- Integrated strapping device
- ESD compatibility
- Total brake on 1 or 2 swivel wheels
- RFID & Tracking compatibility
- Corner supports
- Catch for towing one or two lines of Lean dollies
- Wheel spacer

ALSO AVAILABLE IN US-DIMENSIONS

- 32" x 30"

DESIGNED TO CARRY SLC'S, PALLETS AND BOXES

- Pallet sizes:
800 x 600 mm or 32" x 30"
- Cages and foldable boxes

COMPATIBLE WITH ALL LEAN DOLLIES, LEAN SHELF WAGON AND TAXILINER.



**Watch
the video**

Lean Pallet Size Dolly with elevated deck



TECHNICAL SPECIFICATION	
External dimensions	1200 x 800 x 600 mm
Tare weight	89 kg
Wheel size	160 mm wheels
Wheel configuration	2 fixed & 2 swivel 4 swivel 2 fixed & 4 swivel
Wheel material	PU and PA
Working capacity	1000 kg
Working capacity in tugger train	4000 kg
Max amount per tugger train	6 units
Surface treatment	Blue zinc plated acc. to EN-ISO2081
Safe stacking	up to 1680 mm with "handlag" (2,4 m)
Recommended max speed	6 km/h

COMPATIBLE WITH ALL LEAN DOLLIES, LEAN SHELF WAGON AND TAXILINER.

OPTIONS

- Available with anti slip material or plywood deck
- Integrated strapping device
- ESD compatibility
- Total brake on 1 or 2 swivel wheels
- RFID & Tracking compatibility
- Corner supports
- 360° spinning on 6 wheels
- Catch for towing one or two lines of Lean dollies
- Wheel spacer
- Forklift guide

ALSO AVAILABLE IN ISO- AND US-DIMENSIONS

- 1200 x 1000 mm (97 kg)
- 48" x 45" (90 kg)

DESIGNED TO CARRY SLC'S, PALLETS AND BOXES

- Pallet sizes: Euro, ISO & 48" x 45"
- SLC's in Euro, ISO or US boxes
- Cages and foldable boxes



**Watch
the video**

Lean Shelf Wagon



TECHNICAL SPECIFICATION

External dimensions	1260 x 806 x 1680 mm
Tare weight (2 shelves + floor)	113 kg
Wheel size	160 mm wheels
Wheel configuration	2 fixed and 2 swivel
Wheel material	PU and CPD
Surface treatment	Blue zinc plated acc. to EN-ISO2081
Working capacity	Per Shelf: 150 kg or 250 kg (heavy-duty) Per Unit: 450 kg or 800 kg (heavy-duty)
Max amount in tugger trains	6 units
Recommended max speed	6 km/h

OPTIONS

- ESD compatibility
- Total brake on 1 or 2 swivel wheels
- RFID & Tracking compatibility
- 6 wheel option for 360° spinning
- Catch for towing one or two lines of Lean dollies
- Wheel spacer
- Forklift guide

DESIGNED TO CARRY SLC'S AND TRAYS AND OTHER BOXES

ACCESSORIES

- Transport & non-contamination cover

COMPATIBLE WITH ALL LEAN DOLLIES, LEAN SHELF WAGON AND TAXILINER.



**Watch
the video**

Lean Taxiliner



3 Bay Version

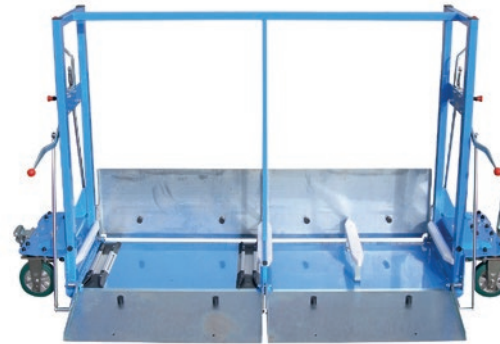

4 Bay Version



TECHNICAL SPECIFICATION	3 Bay Version	4 Bay version
External dimensions	2031 x 1425 x 725 mm	2496 x 1430 x 725 mm
Length including the draw bar	2540 mm	3001 mm
Space between dividers	410 mm	410 mm
Working capacity	750 kg	750 kg
Tare weight	215 kg	282 kg
Maximum Train load	2250 kg	2250 kg
Maximum speed	15 km/h	12 km/h
Min. turning circle	3800 mm	4350 mm
Ramp elevation for Dollies	72 mm	80 mm
Ground clearance	40 mm	38 mm
Steering system SpurTrak™	All wheel Steer	All wheel Steer
Surface treatment	Powder coating	Powder coating

DESIGNED TO CARRY

- 600 x 400 mm and 600 x 800 mm Dollies
- Also ISO and US sized Dollies

BENEFITS

- Ideal for logistic flows where the sequence cannot be controlled
- Reduce handling costs
- Enables the delivery of multiple article numbers in one delivery sequence
- Improve ergonomics
- Fast and safe internal transport
- Excellent tracking and steering stability

OPTIONS

- Non-slip feature for the ramps
- Double locking device
- Additional floor guidance
- ESD compatibility
- RFID & Tracking compatibility

COMPATIBLE WITH ALL LEAN PALLET SIZE DOLLY AND LEAN SHELF WAGON.



Watch the video



K&A TWALL
Logistics Efficiency through Innovation

JOHN DEERE

STANLEY



Watch the video

TECHNICAL SPECIFICATION

External dimensions	820 x 620 mm, height when down/up 290/350 mm 1220 x 820 mm, height when down/up 290/350 mm 1220 x 1010 mm, height when down/up 290/350 mm
Ground clearance when down/up	0/60 mm
Tare weight with CPD wheels, no corners	18 kg
Wheel size	200 mm wheels
Wheel configuration	2 per wagon
Wheel material	PU
Maximum Load Capacity	1000 kg
Tare weight	approx. 180 kg
Coupling:	
- Length	200 mm
- Type	A&A crossbar coupling system
Maximum speed	16 km/h
Surface treatment	Powder coating
Time to lift	Less than 3 seconds

BENEFITS

- Easy one man operation
- No turnaround needed
- Extremely manoeuvrable
- No additional routing needed
- Safe and high track stability
- Loading/unloading from both sides

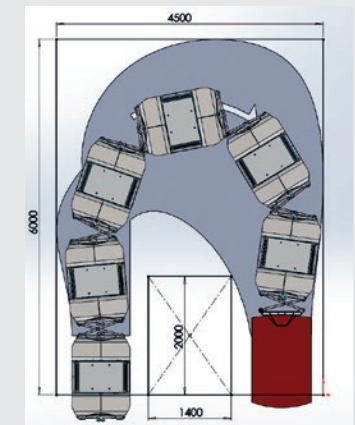
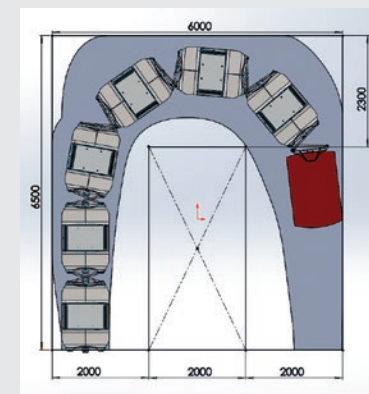

elephantboard[®] and daughter cart for the LiftLiner[®]



TECHNICAL SPECIFICATION ELEPHANTBOARD (4 SHELVES)	
External dimensions	820 x 1450 x 1810 mm
Maximum working capacity	500–1000 kg
Shelf material	Rotomoulding plastic
Distance between shelves	365 mm
Tare weight	65 kg
Wheel type	2 swivel and 2 fixed
Wheel material	Heavy-duty polyurethane wheels
Wheel size	200 mm
Surface treatment	Blue Zinc Plated
Amount per LiftLiner	1 unit

TECHNICAL SPECIFICATION DAUGHTER CART	
External dimensions	840 x 1240 x 318 mm
Maximum working capacity	1000 kg
Tare weight	29 kg
Wheel type	2 fixed and 2 swivel or 4 swivel
Wheel material	Polyamide wheels
Wheel size	200 mm
Surface treatment	Blue Zinc Plated
Amount per LiftLiner	1 unit

Available with 1 to 4 shelves and in ISO size.

BENEFITS

- Eliminate the need for forklifts and reduce the risk of accidents at manufacturing and assembly lines
- Lower maintenance costs
- Reduce overall operator costs
- Require only one operator making multiple deliveries on one route trip
- Enable to carry smaller and kitted loads in addition to pallet units in the same train
- Faster delivery rates - takes seconds to unload



Watch the video

Accessories – Wheel overview

Ø 100 MM WHEELS



CPD WHEEL



RUBBER WHEEL



POLYURETHANE WHEEL



ESD RUBBER WHEEL



**ESD HYBRID WHEEL
NON-MARKING**



**ESD POLYURETHANE
WHEEL**



CLEAN WHEEL

Ø 160 MM WHEELS



POLYURETHANE WHEEL



SOLID WHEEL PA

- All our wheels are equipped with ball bearings to ensure
 - lower rolling resistance
 - lower noise
 - long life span
- Very high load capacity and quality
- The wheels are designed to be used also in a tugger train





**MULTIPURPOSE DECK
FOR 600 X 800 MM LEAN DOLLIES**

TECHNICAL SPECIFICATION	
External dimensions	598 x 798 mm
Material	Coated plywood
Max. load	500 kg
Supplied	Ready to use

DESIGN

- Compatible with 600 x 800 mm Lean Dollies

BENEFITS

- Provides a close deck for smaller packages
- Easy to use
- Equipped with two ergonomic handles



**ERGONOMIC HANDLE
FOR TOWING OF DOLLIES**

TECHNICAL SPECIFICATION	
External dimensions	470 (L) x 405 (W) x 900 (H) mm
Surface treatment	Blue zinc plating
Weight	5 kg
Wheel type and size	CPD 100 mm
Supplied	Ready to use

DESIGN

- Both for 600 x 400 mm and 600 x 800 mm Lean Dollies

BENEFITS

- Ergonomic and safe way to move the dollies



**EASY STRAP
FOR LEAN ADAPTOR PALLET**

TECHNICAL SPECIFICATION	
Modular length	2300 – 3800 mm
Material	Textile with metal hook
Max. load to be tripped	1000 kg = max. load to be distributed on one or more Adaptor Pallets
Max. load by stacking	1000 kg in total
Supplied	Ready to use and to be attached to the Adaptor Pallet.

DESIGN

- Adjustable length
- Directly attached to the Lean Adaptor Pallet

BENEFITS

- Safer transportation
- Easy to attach
- Reusable

To be used in connection with the Lean Adaptor Pallet and secure the transported boxes.



**COVER
FOR LEAN SHELF WAGON**

TECHNICAL SPECIFICATION	
External dimensions	806 x 1260 x 1680 mm
Material	PVC (polyvinyl chloride)
Packing	Delivered as complete kit for 1 unit
Supplied	Delivered ready for use and to be attached to the Lean Shelf Wagon

Designed for closed transportation of the Lean Shelf Wagon between warehouses or from for example unloading areas outside to inside. The cover is very easy to flip over and open as well as closing.

DESIGN

- Access from both long and short sides if needed
- Easy manual handling due to Velcro-closing
- Flip-up and attach sides for less space consuming handling

BENEFITS

- Weather protection
- Protection against contamination
- Transport safety under truck transportation
- Internal transport safety
- Easy manual handling
- Space friendly solution



**DRIPPING PAN
FOR 600 X 400 MM LEAN DOLLIES**

TECHNICAL SPECIFICATION	
External dimensions	604 x 404 mm
Material	PVC (Polyvinyl chloride)
Supplied	Ready to use

Designed to be placed between the Dolly and the packages transported.

BENEFITS

- Prevents liquid dripping from boxes on the floor
- Prevents accidents
- The Dolly stays stackable while being attached with the dripping pan



**TOW TRACTOR
DRAW BAR**

TECHNICAL SPECIFICATION	
Max. load on the draw bar	6000 kg
Max. load on the pin	2000 kg
Compatible with	Lean Dolly 600 x 500 mm Lean Dolly 600 x 400 mm Lean Dolly 600 x 800 mm Lean Dolly 600 x 1000 mm Lean Pallet Size Dolly Lean Shelf Wagon
Surface treatment	Blue zinc plated
Supplied	Assembled ready to mount on the tugger

DESIGN

For the tractor types:
Jungheinrich EZS350 and Linde P30/P50.
It can also be adjusted for other tractor types.

BENEFITS

- Enable towing of all Lean Dollies in various combinations.





TECHNICAL SPECIFICATION

Drive concept	Omnidrive
Type	lifting fork
Max driving speed	5.4 km/h or 1.5 m/s
Lifting height	1100 mm (max shelf height 1000 mm)
Load capacity	1000 kg
Fork length	1200 mm
Fork width	559 mm
Turning radius	2200 mm
Ground clearance	12 mm
Unit tare weight	800 kg
Lift and transports	all load carriers such as roll cages, pallets, foldable cages
Height	1915 mm
Width	800 mm
Length	1654 mm



BENEFITS

- Slim design
- Omnidrive
- Free navigation
- 360° safety
- Long lasting Li-Ion battery
- Electric free lift



Watch
the video



CREATING FUTURE-FIT
**SMART
MOVES**
LOGISTIC SOLUTIONS

K. HARTWALL

Electric Tugs

Standard with
LITHIUM
TECHNOLOGY



T1000

TECHNICAL SPECIFICATION	
Power	DC motor 24V, 300W
Maximum pulling force	Up to 1000 kg
Battery	Exchangeable, 24 Volt, 20 Ah Lithium LiFePo4
Maximum speed	4,8 km/h, programmable
Tires	Full rubber ø250x80 mm

BENEFITS

- Very manoeuvrable
- Easy to use
- Interchangeable Lithium battery pack

Standard with
LITHIUM
TECHNOLOGY



T1500

TECHNICAL SPECIFICATION	
Power	DC motor 24V, 600W
Maximum pulling force	Up to 1500 kg
Battery	Exchangeable, 24 Volt, 20 Ah Lithium LiFePo4
Maximum speed	4,8 km/h, programmable
Tires	Full rubber ø250x80 mm

BENEFITS

- Compact
- Easy to use
- Interchangeable Lithium battery pack

Available with
LITHIUM
TECHNOLOGY



T2500

TECHNICAL SPECIFICATION	
Power	DC motor 24V, 600W
Maximum pulling force	Up to 2500 kg
Battery	Built-in 24 Volt, 75 Ah
Maximum speed	4,8 km/h, programmable
Tires	Full rubber ø250x80 mm

BENEFITS

- Versatile
- Easy to use
- Available with Lithium batteries

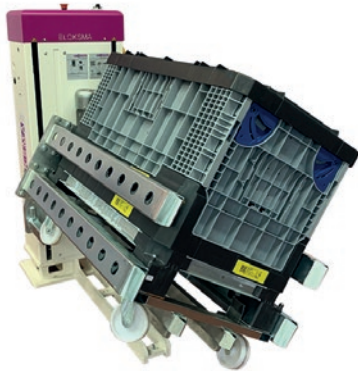

FRONTLOADING LIFTER



SIDELADING LIFTER



SUPERMARKET

TECHNICAL SPECIFICATION	
External dimensions	approx 850 x 1.700
Designed for	Lean Palett Size Dolly 1200x800 mm. Possible for other dimensions on request
Lifting capacity	max. 1.000 kg
Power	230 V (Other voltage strengths possible on request)
Loading direction	Front loading – lengthwise
Surface	Body: Powder coating – Lifting device: zinc coating
Other options	other size for Dolly (800x600 mm / 1200x1000 mm), other loading direction partly with tilt functions

TECHNICAL SPECIFICATION	
External dimensions	approx 580 x 975 mm
Designed for	Lean Palett Size Dolly Typ I / II / V / VII or Inch size 16x24. Possible for other dimensions on request
Lifting capacity	200 kg or 300 kg
Power	230 V (Other voltage strengths possible on request)
Loading direction	Front loading – lengthwise – crosswise side loading left or side loading right
Surface	Body: Powder coating – Lifting device: zinc coating
Other options	Sensory height detection - automatic mode, other size for Dolly (400x400 mm or 800x600 mm), other loading direction partly with tilt functions

TWO OPTIONS

1. You buy single components and create your supermarket yourself.
 2. You send your case – we do the design for you. According to the principle: plug and play
- If required, we also build the supermarket for you in your plant

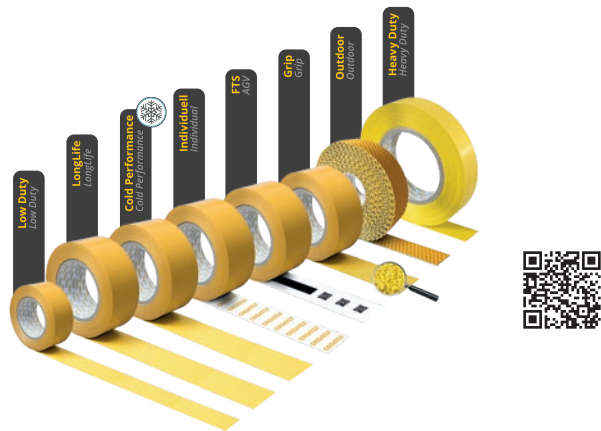

LongLife Floor Marking Tape

TECHNICAL SPECIFICATION	
Adhesive strength	3,65 N/cm – 27,4 N/cm
Thickness	0,16 mm – 2,8 mm
Temperature range	-40°C – +120°C
Widths	50 mm – 100 mm

DESIGN

Available in different colors, sizes and surfaces

BENEFITS

sticks quickly, durable, for various substrates



eOX-Spot

TECHNICAL SPECIFICATION	
Luminous flux of the projector	1.150 Lumen
Luminous duration	35.000 hours
Input Voltage	220 – 240 V AC, 50 / 60 Hz
Ambient temperature	-30 °C to +35 °C

DESIGN

Steel, Aluminium, powder coated, active cooling

BENEFITS

High-Power-LED, quickly interchangeable motifs, use on wall and ceiling



eOX-Station

TECHNICAL SPECIFICATION	
Voltage	240 VDC
Sensors	Magnetic Hall Sensors
Reaction time	< 1 Sek.
Maximum number of tracks	120

DESIGN

Compatible with Lean Dollies

BENEFITS

FiFo station digitally enhanced, pick-by-light, calculation of the FiFo-Logic, input and output detection



TECHNICAL SPECIFICATION	
Order number	BG10009401
Size per unit (L×W×H)	535 x 210 x 140 mm
Power	40 W, 2.0 A
Max. total load	180 kg
Environmental temperature	-10 ~ 40° C
Humidity	10 ~ 90 % RH (no condensate)
Construction requirement	Plane, clean hall floor with min. 20 N / mm ² compressive strength (concrete strength class C20/25 t C50/60; uncracked)

The concept of the monomover

Compatible with all common fifo station systems

The monomover automatically transports all types of dollies within your staging yard. In this way, the supplies can be transported fully automatically to the pick-up point at the right time.

Fits to your growing needs

Thanks to the modular design, you can easily adapt the units to your individual track length. Thanks to the built-in sensor technology, the individual transport sections are approached independently.

Compatible with certain AGVs

The possibility of representing transfer situations with certain AGV systems is another highlight that allows you to optimize the efficiency of your FIFO station.

Equipped for digitalisation with ProfiNet interface

Thanks to the connection to PLC systems via the ProfiNet interface, the system can be used as a fully automated and digital Kanban system.

The advantages of the monomover

- Automated feed unit
- PLC connection possible
- Modular conception
- Compatible with certain AGVs
- Compact, robust and durable
- Flexible track length adjustment
- Supports lean principles
- Retrofit in all common Station Systems

MAKE THE NEXT
SMART MOVE
IN LOGISTICS

COST SAVINGS
UP TO 40 %

PRODUCTIVITY
INCREASED BY
UP TO 55%

3-4 TIMES LESS
MANUAL HANDLING
OPERATIONS
PER TOTE

BETTER
SAFETY AND
ERGONOMICS



DAIMLER

MAHLE



BOSCH

SCHAEFFLER



brose
Technik für Automobile

Continental